

プロセストランスミッタ

圧力ポート付 モデルUPT-20

フラッシュダイヤフラム付 モデルUPT-21

WIKAデータシートPE 86.05



承認については、10ページを参照してください。



アプリケーション

- 制御・プロセス技術
- 機械建築・プラント建設
- 医薬品・衛生産業
- 食品産業
- 化学・石油化学工業

特徴

- 多機能ディスプレイ
- シンプルなメニューナビゲーション
- 導電性プラスチックケースまたはステンレススチールケース (オプションで表面の電解研磨)
- 大型液晶ディスプレイ(回転可能)
- ATEX, IECEx等の防爆エリアでの使用が可能



図左: プラスチックケース
図右: 電解研磨ステンレスケース

説明

計器構造

モデルUPT-2xプロセストランスミッタはインテリジェントセンサを必要とするアプリケーションのために開発されました。特に、集積化された温度補償は、プロセストランスミッタを広範囲のアプリケーションにとって興味深いものにする。

測定セルはステンレススチール316L、または高品質Elgiloy®との組み合わせで作られています。特定の要求については、さらに特別な材質も利用可能です。

ケースを330°回転させることができ、LCディスプレイは90°単位で配置変更かのです。LCディスプレイは、最大5mの距離で、どの取付位置でも読みやすいです。

Elgiloy®は「特殊金属」の商標です。

HART®プロトコル

プロセストランスミッタは、アナログ技術を使用するアプリケーションと、HART™プロトコルを介して通信する最新のシステムの両方に設置することができます。

ディスプレイ及び操作モジュールまたはHARTインターフェースを介して、このプロセストランスミッタは現場で直接、またはプロセスコントロールシステムを介して遠隔でも構成が可能です。

ターンダウン

調整可能なターンダウンにより、正確なプロセス値を、測定値の最適化された限界値と共に、制度の大きな制約なしに登録することができます。

Specifications

Measuring ranges

Gauge pressure						
bar	0 ... 0.4	0 ... 1.6	0 ... 6	0 ... 16	0 ... 40	0 ... 100
	0 ... 250	0 ... 600	0 ... 1,000	0 ... 1,600	0 ... 2,500	0 ... 4,000
psi	0 ... 10	0 ... 15	0 ... 30	0 ... 100	0 ... 300	0 ... 500
	0 ... 1,500	0 ... 5,000	0 ... 10,000	0 ... 15,000	0 ... 30,000	0 ... 50,000
	0 ... 60,000					

Absolute pressure						
bar	0 ... 1.6	0 ... 6	0 ... 16	0 ... 40		
psi	0 ... 30	0 ... 100	0 ... 300	0 ... 500		

Vacuum and +/- measuring ranges						
bar	-1 ... 0	-0.2 ... +0.2	-1 ... +0.6	-1 ... +5	-1 ... +15	-1 ... +40
psi	-14.5 ... 0	-14.5 ... +15	-14.5 ... +100	-14.5 ... +300	-14.5 ... +600	

For measuring ranges above 600 bar [10,000 psi] only the model UPT-20 is available.

Other measuring ranges can be set via turndown.

For example, a 0 ... 6 bar [0 ... 100 psi] instrument can also be used from -1 ... +6 bar [-14.5 ... +100 psi].

Values of less than 0 bar abs. [0 psia] cannot be set or measured.

Vacuum/overload safety	
Vacuum safety	Yes (not for oxygen applications)
Overload safety (standard version, version with cooling element)	
Measuring range \leq 40 bar [500 psi]	3 times
Measuring range 40 ... 1,000 bar [500 ... 15,000 psi]	2 times
Measuring range 1,600 bar [30,000 psi]	1.5 times
Measuring range 2,500 bar [50,000 psi]	1.4 times
Measuring range 4,000 bar [60,000 psi]	1.25 times

Output signals

Output signals	
Signal types	<ul style="list-style-type: none"> ■ 4 ... 20 mA ■ 4 ... 20 mA with HART® signal (option)
Load in Ω	<ul style="list-style-type: none"> ■ $\leq U_+ - 12 \text{ V} / 0.023 \text{ A}$ (non-Ex) ■ $\leq U_+ - 14 \text{ V} / 0.023 \text{ A}$ (Ex) <p>U_+ = Applied supply voltage (\rightarrow see "Supply voltage")</p>
Dampening	<p>0 ... 99.9 s, adjustable</p> <p>After the set dampening time the instrument outputs 63 % of the applied pressure as output signal.</p>
Settling time t_{90}	
Without HART®	60 ms
With HART®	80 ms
Refresh rate	
Without HART®	20 ms
With HART®	50 ms

Accuracy specifications

Accuracy specifications		
Accuracy at reference conditions ¹⁾	<ul style="list-style-type: none"> ■ 0.15 % of span ■ 0.1 % of span (option 1) ■ 0.2 % of span (option 2) ■ 0.5 % of span (> 1,000 bar [15,000 psi]) (option 3) 	
Adjustability		
Zero point	-20 ... +95 % (downwards, the adjustability is always limited by the minimum pressure of 0 bar abs. [0 psia])	
Span	Measuring range ≤ 1,000 bar [15,000 psi]	-120 ... +120 % with a difference between zero point and span of max. 120 % of the nominal measuring range
	Measuring range > 1,000 bar [15,000 psi]	Max. (0 bar abs. [0 psia]) ... +105 % (downwards, the adjustability is always limited by the minimum pressure of 0 bar abs. [0 psia])
Turndown	Unlimited	
	Measuring range ≤ 1,000 bar [15,000 psi]	Maximum recommended turndown 20:1
	Measuring range > 1,000 bar [15,000 psi]	Maximum recommended turndown 2:1
Mounting correction	-20 ... +20 %	
Non-repeatability		
Measuring ranges ≤ 1,000 bar [15,000 psi]	≤ 0.1 % of span	
Measuring ranges > 1,000 bar [15,000 psi]	≤ 0.5 % of span	
Behaviour with turndown ²⁾		
Measuring ranges from 0 ... 1.6 bar to 0 ... 1,000 bar [0 ... 25 psi to 0 ... 15,000 psi]	TD ≤ 5:1	No influence on the accuracy
	TD > 5:1 ... ≤ 100:1	GES = GG x TD / 5
Measuring range < 1.6 bar [30 psi]	TD = 1:1	No influence on the accuracy
	TD > 1:1 ... ≤ 100:1	GES = GG x (TD + 4) / 5
Measuring range > 1,000 bar [15,000 psi]	≤ 0.5 x TD	
Long-term stability		
Measuring range < 1 bar [14.5 psi]	0.35 %/year	
Measuring range ≥ 1 bar [14.5 psi]	0.15 %/year	
Measuring range ≥ 1.6 bar [30 psi]	0.1 %/year	
Measuring range ≥ 40 bar [600 psi]	0.1 %/year	
Measuring range > 1,000 bar [15,000 psi]	≤ 0.5 %/year	
Thermal change, zero point / span (reference temperature 20 °C [68 °F])		
In the temperature-compensated range 10 ... 70 °C [50 ... 158 °F]	No additional temperature error (only applies to measuring range up to 1,000 bar [15,000 psi])	
Outside compensated range	Typical < 0.1 %/10 K (for > 1,000 bar [15,000 psi]: 0.2 %/10 K)	
Thermal change of the current output (reference temperature 20 °C [68 °F])		
< 18 °C and > 28 °C [< 64 °F and > 82 °F]	0.1 %/10 K (max. 0.15 %/10 K)	

1) Including non-linearity, hysteresis, zero offset and end value deviation (corresponds to measured error per IEC 61298-2).

2) **Legend**

GES: Overall accuracy via turndown

GG: Accuracy (e.g. 0.15 %)

TD: Turndown factor (e.g. 4:1 corresponds to TD factor 4)

Reference conditions (per IEC 61298-1)

Reference conditions (per IEC 61298-1)	
Temperature	23 °C ± 2 °C [73 °F ± 7 °F]
Supply voltage	DC 23 ... 25 V
Atmospheric pressure	860 ... 1,060 mbar [86 ... 106 kPa, 12.5 ... 15.4 psi]
Air humidity	45 ... 75 % r. h.
Characteristic curve determination	Terminal method per IEC 61298-2
Curve characteristics	Linear
Reference mounting position	Vertical, diaphragm points downward

Voltage supply

Voltage supply	
Voltage supply (non-Ex)	
Supply voltage U ₊	DC 12 ... 36 V
Voltage supply (Ex)	
Supply voltage U ₊	DC 14 ... 30 V
Maximum voltage U _i	DC 30 V
Maximum current I _i	100 mA
Maximum power P _i (gas)	1,000 mW
Maximum power P _i (dust)	750/650/550 mW (depending on the max. ambient temperature)
Effective internal capacitance	11 nF
Effective internal inductance	100 µH

→ For more information, see "Approvals"

Process connections

With pressure port (for model UPT-20)

Per standard	Thread size	Possible measuring ranges
EN 837	G 3/8 B	≤ 0 ... 1,000 bar [0 ... 15,000 psi]
	G 1/2 B	≤ 0 ... 1,000 bar [0 ... 15,000 psi]
	M20 x 1.5	≤ 0 ... 1,000 bar [0 ... 15,000 psi]
ANSI / ASME B1.20.1	1/2 NPT	≤ 0 ... 1,000 bar [0 ... 15,000 psi]
	1/2 NPT, female	≤ 0 ... 1,000 bar [0 ... 15,000 psi]
	1/4 NPT	≤ 0 ... 1,000 bar [0 ... 15,000 psi]
-	M16 x 1.5 mm female with sealing cone	≥ 0 ... 100 bar [0 ... 1,500 psi]
	M20 x 1.5 mm female with sealing cone	≥ 0 ... 1,600 bar [0 ... 23,200 psi]
	9/16-18 UNF female F 250-C	≥ 0 ... 100 bar [0 ... 1,500 psi]
	1 1/8 -12 UNF female F 562-C	≥ 0 ... 100 bar [0 ... 1,500 psi]

With flush diaphragm (for model UPT-21)

Per standard	Thread size	Possible measuring ranges
-	G ½ B	0 ... 6 to 0 ... 600 bar [0 ... 100 to 0 ... 5,000 psi]
	G 1 B	≤ 0 ... 1.6 bar [0 ... 30 psi]
	G 1 ½ B	≤ 0 ... 1.6 bar [0 ... 30 psi]
	G 1 hygienic ¹⁾²⁾	≤ 0 ... 16 bar [0 ... 100 psi]
	G 1 hygienic with cooling element ²⁾	≤ 0 ... 16 bar [0 ... 100 psi]
	M44 x 1.25 with union nut	≤ 0 ... 40 bar [0 ... 500 psi]
TRI-CLAMP®	DN 1½ with cooling element for 150 °C [302 °F]	≤ 0 ... 40 bar [0 ... 500 psi] ⁴⁾
	DN 2 with cooling element for 150 °C [302 °F]	≤ 0 ... 40 bar [0 ... 500 psi] ⁴⁾
Clamp DIN 32676	DN 40 with cooling element for 150 °C [302 °F]	≤ 0 ... 40 bar [0 ... 500 psi] ⁴⁾
	DN 50 with cooling element for 150 °C [302 °F]	≤ 0 ... 40 bar [0 ... 500 psi] ⁴⁾
Grooved union nut DIN 11851 with conical coupling ³⁾	DN 25 with cooling element for 150 °C [302 °F]	≤ 0 ... 40 bar [0 ... 500 psi]
	DN 50 with cooling element for 150 °C [302 °F]	≤ 0 ... 25 bar [0 ... 500 psi]
NEUMO BioConnect®	DN 40 form V with cooling element for 150 °C [302 °F]	≤ 0 ... 16 bar [0 ... 500 psi]
VARIVENT®	Form N with cooling element for 150 °C [302 °F] DN 40 ... 50	≤ 0 ... 16 bar [0 ... 500 psi]
	Form F with cooling element for 150 °C [302 °F] DN 25	≤ 0 ... 16 bar [0 ... 500 psi]

BioConnect® is a registered trademark of the company NEUMO.
VARIVENT® is a registered trademark of GEA Tuchenhagen GmbH.

- 1) Also available as a high-temperature version up to 150 °C [302 °F].
- 2) Suitable for WIKA adapter system model 910.61; → see data sheet AC 09.20
- 3) For a 3-A compliant connection of process connections with milk thread fittings per DIN 11851, profile sealings from SKS Komponenten BV or Kieselmann GmbH have to be used.
- 4) For the maximum pressure, the permissible pressure rating of the clamp must be observed.

Pressure transmission medium

Model	Medium
Model UPT-20	Measuring range ≤ 40 bar [500 psi]: Synthetic oil (halocarbon oil for oxygen applications)
	Measuring range > 40 bar [500 psi]: Dry measuring cell
Model UPT-21	Synthetic oil

一般的に、酸素用途では、ハロカーボンオイル。表面のオイル及びグリースが完全を完全に取り除く特別な洗浄プロセスが要求される。必要に応じて、オプションとして食品産業のためのFDAリストメディアが利用可能である。

ダイヤフラムシール

ダイヤフラムシールを仕様することにより、モデルUPT-20プロセストランスミッタをプロセス産業におけるもっとも困難な条件にさえ適合させることが可能である。したがって、トランスミッタは、極端な温度で、浸食性、腐食性、不均一性、研磨性、高粘性又は毒性の媒体と共に使用することができる。多種多様な無菌接続(クランプ、ねじ付きパイプ、DIN11864無菌接続など)の結果、測定アセンブリは滅菌プロセスエンジニアリングの高い要求をも満たす。



Materials

	Measuring ranges	Process connections	Materials	
Wetted parts				
UPT-20	≤ 40 bar [500 psi]	All	Standard	Process connection: Stainless steel 1.4404 / 316L Sensor: Stainless steel 1.4404 / 316L
	> 40 bar [500 psi]	All	Standard	Process connection: Stainless steel 1.4404 / 316L Sensor: Elgiloy® 2.4711
	> 1,000 bar [15,000 psi]	All	Standard	Process connection: Stainless steel 1.4534 / 904L Sensor: Stainless steel 1.4534 / 904L
UPT-21	All	All	Standard	Process connection: Stainless steel 1.4435 / 316L Diaphragm: Stainless steel 1.4435 / 316L
		■ G ½ ■ G 1	Option 1	Process connection: Hastelloy® HC276 / 2.4819 Diaphragm: Hastelloy HC276 / 2.4819
		■ G ½ ■ G 1	Option 2	Process connection: Gold-plated Diaphragm: Gold-plated ¹⁾

1) Accuracy 0.1 % not available for gold-plated sensors.

All connections are NACE MR0103 and MR0175 compatible. No NACE for measuring ranges > 1,000 bar [15,000 psi] (→ see page 11)

Elgiloy® is a trademark of the company "Specialty Metals"

水素用途

水素の測定には、金メッキしたダイヤフラムを用いることが望ましい。これが技術的に不可能であれば、長期的なドリフトが大きくなることが予想される。

私たちの技術サポートは、質問に応じて利用できます。1,600bar以上の圧力での使用は推奨されない

Sealing material

→ See table under Operating conditions, medium temperature

Case	
Option 1	Plastic (PBT) with conductive surface per EN 60079-0:2012 Colour: Night blue RAL5022
Option 2	Stainless steel case 1.4308 (CF-8), precision cast (suitable for chemical and petrochemical industries)
Option 3	Stainless steel case 1.4308 (CF-8) with electropolished surface (suitable for pharmaceutical, food and hygienic industries)
Option 4 ¹⁾	Stainless steel case coated with epoxy resin
Option 5 ¹⁾	Stainless steel case, electropolished and coated with epoxy resin

1) Not suitable for Ex applications.

Electrical connection

Electrical connection		
Spring-loaded terminals	Wire cross-section: Wire or strand: 0.2 ... 2.5 mm ² (AWG 24 ... 14) Strand with end splice: 0.2 ... 1.5 mm ² (AWG 24 ... 16)	
Cable glands M20 x 1.5		
Plastic, PA	Sealing	NBR
	Cable diameter	6 ... 12 mm [0.24 ... 0.47 in]
	Ingress protection	IP66/67
Brass, nickel-plated	Sealing	NBR
	Cable diameter	5 ... 9 mm [0.2 ... 0.35 in]
	Ingress protection	IP66/67
Stainless steel cable gland	Sealing	NBR
	Cable diameter	7 ... 12 mm [0.28 ... 0.47 in]
	Ingress protection	IP66/67
Stainless steel cable gland in hygienic design	Sealing	FDA compliant
	Cable diameter	6 ... 12 mm [0.24 ... 0.47 in]
	Ingress protection	IP66/67
Angular connector DIN 175301-803A with mating connector	Wire cross-section	Max. 1.5 mm ² (AWG 16)
	Ingress protection	IP65 ¹⁾
Circular connector M12 x 1 (4-pin) without mating connector	Ingress protection	IP65 ¹⁾
Electrical safety	Reverse polarity protection	

1) The stated ingress protection only applies when plugged in using mating connectors that have the appropriate ingress protection.

Connection diagrams

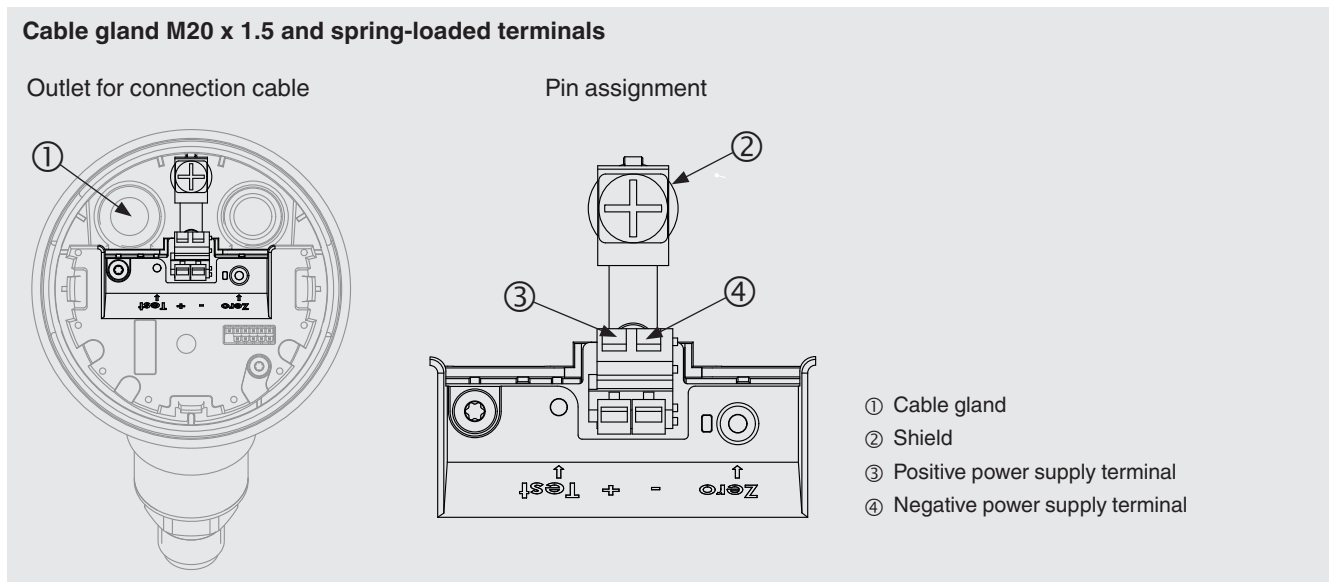

Legend

- U₊ Positive power supply terminal
- U₋ Negative power supply terminal

Display and operating unit, model DI-PT-U (option)

Display and operating unit, model DI-PT-U (option)	
Display type	LC display ¹⁾
Refresh rate	200 ms
Main display	4 ½-digit
Segment display	Character size 14 mm [0.55 in]
Additional display	Selectable via menu, three-line scale range
Bar graph display	20 segments, radial, pressure gauge simulation
Adjustable units	
Pressure units	<ul style="list-style-type: none"> ■ bar ■ psi ■ mbar ■ MPa ■ kPa ■ hPa ■ Pa ■ mH₂O ■ mmH₂O ■ ftH₂O ■ inH₂O ■ mHg ■ mmHg ■ inHg ■ kg/cm² ■ g/cm² ■ Torr
Level units	<ul style="list-style-type: none"> ■ m ■ cm ■ mm ■ ft ■ in
Volume units	<ul style="list-style-type: none"> ■ l ■ m³ ■ gal ■ inch³ ■ ft³ ■ %
Free unit	A free character string (6 characters) can be defined as a unit
Operating state	Display via symbols
Operating temperature	By using the display and operating unit, the operating temperature is limited to -20 ... +60 °C [-4 ... +140 °F]
Storage temperature	-40 ... +80 °C [-40 ... +176 °F]
Operation	4 buttons for the recall and operation of the settings
Colours	
Background	Light grey
Digits	Black
Upgradable	Yes (→ see "Accessories")
Display size	Separated into main and segment displays
Ingress protection per IEC/EN 60529	<ul style="list-style-type: none"> ■ IP20 (loose) ■ IP40 (built-in without cover)
Material	Case from ABS, window from polyester film

1) For the process transmitter only this display may be used. → For order number see Accessories.

Operating conditions

Operating conditions	
Range of applications	Suitable for internal and external operation, exposure to direct sunlight is permitted
Permissible air humidity	≤ 93 % r. h.
Permissible temperature ranges	
Ambient	<ul style="list-style-type: none"> ■ -20 ... +60 °C [-4 ... +140 °F] (with digital display) ■ -40 ... +80 °C [-40 ... +176 °F] ¹⁾ (without digital display)

Operating conditions		
Medium	Oxygen application	-20 ... +60 °C [-4 ... +140 °F]
	Model UPT-20	<ul style="list-style-type: none"> ■ -40 ... +85 °C [-40 ... +185 °F] ■ -40 ... +105 °C [-40 ... +221 °F] at max. 40 °C [104 °F] ambient temperature ■ -40 ... +120 °C [-40 ... +248 °F] at max. 30 °C [86 °F] ambient temperature
	UPT-21 without cooling element	<ul style="list-style-type: none"> ■ 85 °C [185 °F] at max. 80 °C [176 °F] ambient temperature ■ 105 °C [221 °F] at max. 40 °C [104 °F] ambient temperature ■ 120 °C [248 °F] at max. 30 °C [86 °F] ambient temperature
	UPT-21 with cooling element	<ul style="list-style-type: none"> ■ 85 °C [185 °F] at max. 80 °C [176 °F] ambient temperature ■ 120 °C [248 °F] at max. 50 °C [122 °F] ambient temperature ■ 150 °C [302 °F] at max. 40 °C [104 °F] ambient temperature
Storage	-40 ... +80 °C [-40 ... +176 °F]	
Restrictions to medium temperature due to sealing material (only for model UPT-21)		
NBR	-20 ... +105 °C [-4 ... +221 °F]	
FKM	-20 ... +105 °C [-4 ... +221 °F]	
FKM	-20 ... +150 °C [-4 ... +302 °F] ²⁾	
EPDM	-40 ... +105 °C [-40 ... +221 °F]	
EPDM	-40 ... +150 °C [-40 ... +302 °F] ¹⁾	
Vibration resistance per EN 60068-2-6	4 g (5 ... 100 Hz) per GL characteristic curve 2	
Shock resistance		
Measuring range ≤ 1,000 bar [15,000 psi]	150 g (3.2 ms) per IEC 60068-2-27	
Measuring range > 1,000 bar [15,000 psi]	20 g at 4.6 ms	
Ingress protection	<ul style="list-style-type: none"> ■ IP66/67 ■ IP65 (version with circular connector, angular connector or overvoltage protection) <p>The ingress protection only applies with closed case head and closed cable glands.</p>	
Explosion protection	→ See approvals	

1) Instrument with angular connector or circular connector: -30 ... +80 °C [-22 ... +176 °F]

2) Process connection with cooling element

Additional specifications for temperature ranges for Ex protection











For Ex instruments, the following temperature ranges apply, in addition to the temperature ranges for non-Ex instruments. Temperature class / surface temperatures for all variants **without** cooling element:



Temperature class / surface temperature	Ambient and medium temperature
T5, T6	-40 ≤ Ta ≤ +60 °C [-40 ≤ Ta ≤ +140 °F]
T4	-40 ≤ Ta ≤ +80 °C [-40 ≤ Ta ≤ +176 °F]
T135 °C [T257 °F]	
Pi = 750 mW	-40 ≤ Ta ≤ +40 °C [-40 ≤ Ta ≤ +104 °F]
Pi = 650 mW	-40 ≤ Ta ≤ +70 °C [-40 ≤ Ta ≤ +158 °F]
Pi = 550 mW	-40 ≤ Ta ≤ +80 °C [-40 ≤ Ta ≤ +176 °F]

Temperature class / surface temperatures for all variants **with** cooling element:

Temperature class	Max. medium temperature	Ambient temperature
T4	120 °C [248 °F]	-40 ≤ Ta ≤ +50 °C [-40 ≤ Ta ≤ +122 °F]
T3	150 °C [302 °F]	-40 ≤ Ta ≤ +40 °C [-40 ≤ Ta ≤ +104 °F]

Approvals (option)

Logo	Description	Country
	<p>EU declaration of conformity</p> <p>EMC directive, interference emission (group 1, class B) and immunity per EN 61326-1:2013 (industrial application), EN 61326-2-3:2013¹⁾</p> <p>Pressure equipment directive</p> <p>RoHS directive</p>	European Union
	<p>ATEX directive</p> <p>- Ex i Zone 1 mounting to zone 0 gas [II 1/2G Ex ia IIC T4/T5/T6 Ga/Gb] Zone 1 gas [II 2G Ex ia IIC T4/T5/T6 Gb] Zone 2 gas [II 3G Ex ic IIC T4/T5/T6 Gc] Zone 21 mounting to zone 20 dust [II 1/2D Ex ia IIIC T135 °C Da/Db] Zone 21 dust [II 2D Ex ia IIIC T135 °C Db]</p>	
	<p>IECEX</p> <p>Hazardous areas</p> <p>- Ex i Zone 1 mounting to zone 0 gas [Ex ia IIC T6 ... T3 Ga/Gb] Zone 1 gas [Ex ia IIC T6 ... T3 Gb] Zone 2 gas [Ex ia IIC T6 ... T3 Gc] Zone 21 mounting to zone 20 dust [Ex ia IIIC T135 °C Da/Db] Zone 21 dust [Ex ia IIIC T135 °C Db]</p>	International
	<p>EAC</p> <ul style="list-style-type: none"> ■ Pressure equipment directive ■ Electromagnetic compatibility ■ Hazardous areas <p>- Ex i Zone 1 mounting to zone 0 gas [Ga/Gb Ex ia IIC T6 ... T3 X] Zone 1 gas [1Ex ia IIC T6 ... T3 Gb X] Zone 2 gas [2Ex ic IIC T6 ... T3 GC X] Zone 21 dust [Ex ia IIIC T135°C Db X]</p>	Eurasian Economic Community
	<p>GOST</p> <p>Metrology, measurement technology</p>	Russia
	<p>KazInMetr</p> <p>Metrology, measurement technology</p>	Kazakhstan
	<p>MTSCHS</p> <p>Permission for commissioning</p>	Kazakhstan
	<p>UkrSEPRO</p> <p>Metrology, measurement technology</p>	Ukraine
	<p>DNOP_MakNII</p> <ul style="list-style-type: none"> ■ Mining ■ Hazardous areas <p>- Ex i Zone 1 mounting to zone 0 gas [II 1/2G EEx ia IIC T4/T5/T6 Ga/Gb] Zone 21 mounting to zone 20 dust [II 1/2D IP6X T130 °C/T95 °C/T80 °C]</p>	Ukraine
	<p>Uzstandard</p> <p>Metrology, measurement technology</p>	Uzbekistan
	<p>INMETRO</p> <ul style="list-style-type: none"> ■ Metrology, measurement technology ■ Hazardous areas <p>- Ex i Zone 1 mounting to zone 0 gas [Ex ia IIC T6 ... T3 Ga/Gb] Zone 1 gas [Ex ia IIC T6 ... T3 Gb] Zone 2 gas [Ex ia IIC T6 ... T3 Gc] Zone 21 mounting to zone 20 dust [Ex ia IIIC T135 °C Da/Db] Zone 21 dust [Ex ia IIIC T135 °C Db]</p>	Brazil

Logo	Description	Country
	KCs (KOSHA) Hazardous areas - Ex i Zone 1 to zone 0 [Ex ia IIC T3 ... T6] Zone 1 [Ex ia IIC T3 ... T6] Zone 21 to zone 20 [Ex iD A21 135 °C] Zone 21 [Ex iD A21 135 °C] - Ex n Zone 2 [Ex nL IIC T3 ... T6]	South Korea
	3-A Food This instrument is 3-A marked, based on a third party verification for conformance to the 3-A standard.	International
	EHEDG Hygienic Equipment Design	European Union

1) With electrostatic discharge, a short-term, increased error of up to 1 % of the nominal measuring range can occur.

製造者の情報および証明書

NAMURの勧告

NAMURは、ドイツのプロセス産業の自動化技術利益団体である。公表されたNAMUR勧告は、フィールド計測における標準とみなされており、また国際標準の性格を有している。

本文書は以下のNAMUR勧告の要件を満たしている:

- * NF21-機器の電磁両立性
- * NF43-トランスミッタの故障情報の信号レベル
- * NF53-フィールド機器とディスプレイおよび操作コンポーネントの互換性
- * NF107-フィールド機器の自己監視と診断

>>> 詳しくは、www.namur.net/enを参照してください。

NACE

NACEは腐食の話題に関係する組織(全米腐食技術者協会)の用語である。この組織の結果はNACE標準として公表され、定期的に更新されている。

器具、特に溶接継ぎ目は下記を満たす:

- * NACEMR0103 - 製油所でのアプリケーション
- * NACE MR0175 - オイルの抽出と処理

FDA準拠の充填およびシーリング

FDAは「食品と医薬品」の分野における米国の監督当局であり、市場に出されたすべての製品を管理している。

重要な話題は、食人と接触する物質の仕様である。

ステンレススチールは一般に重要ではないが、食品、医薬品およびバイオテクノロジー応用に使用するプラスチック(シーリング材など)

および液体(圧力伝達媒体など)は、FDAの要件に従って設計しなければならない。

これらの機器に含まれる物質のいくつかは、FDA準拠物質として分類される。

証明書(オプション)

納入品に含まれる測定精度に関する試験成績書(スケール範囲5測定点)

- * 2.2 試験報告書
- * 3.1 検査証明書
- * 規則(EC)1935/2004に関する製造者の宣言
- * 規制(EC) 2023/2006(GMP)に関する製造業者の宣言
- * IEC 17025によるDKD/DAkkS校正

>>> 承認と証明書、ウェブサイト参照

Dimensions in mm [in]

Process connections for model UPT-20

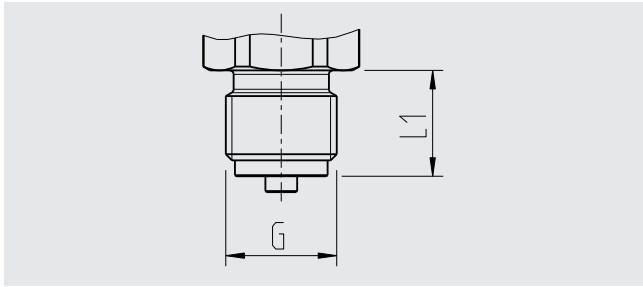

G	L1
G 3/8 B	16 [0.63]
G 1/2 B	20 [0.79]
M20 x 1.5	20 [0.79]

Hexagon dimension: 12 mm [0.47 in]
Spanner width: 27 mm [1.06 in]

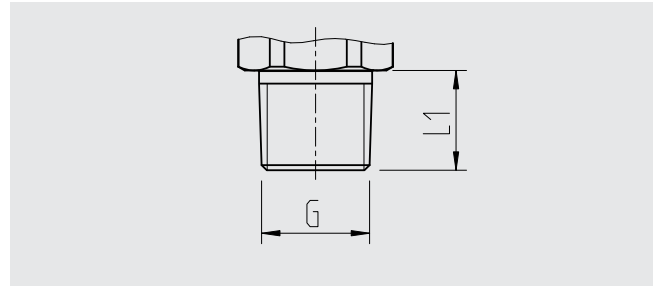

G	L1
1/4 NPT	13 [0.51]
1/2 NPT	19 [0.75]

Hexagon dimension: 12 mm [0.47 in]
Spanner width: 27 mm [1.06 in]

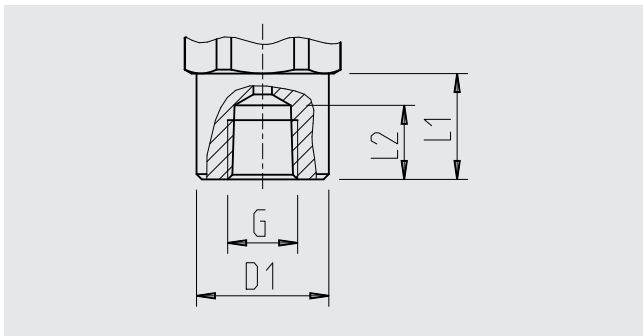

G	L1	L2	D1
Measuring ranges ≤ 40 bar [500 psi]			
1/2 NPT, female	20 [0.79]	19 [0.75]	26.5 [1.04]
Measuring ranges > 40 bar [500 psi]			
1/2 NPT, female	20 [0.79]	19 [0.75]	40.5 [1.59]

Measuring ranges ≤ 40 bar [500 psi]
Hexagon dimension: 10 mm [0.4 in]
Spanner width: 27 mm [1.06 in]

Measuring ranges > 40 bar [500 psi]
Hexagon dimension: 12 mm [0.47 in]
Spanner width: 41 mm [1.61 in]

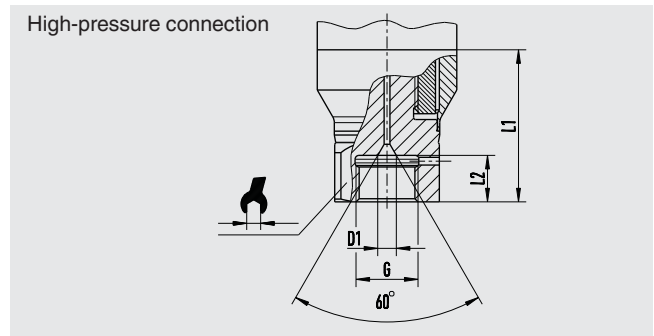

G	L1	D1	SW
M16 x 1.5	12 [0.47]	4.8 [0.19]	27 [1.06]
M20 x 1.5	15 [0.59]	4.8 [0.19]	27 [1.06]

M16 x 1.5 for measuring ranges from 100 bar [1,500 psi] to 4,000 bar [60,000 psi]
M20 x 1.5 for measuring ranges from 1,600 bar [30,000 psi] to 4,000 bar [60,000 psi]

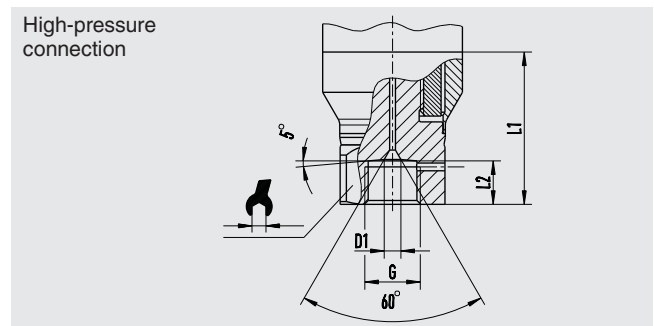

G	L1	D1	SW
9/16-18 UNF female F 250-C	11.2 [0.44]	4.3 [0.17]	27 [1.06]
1 1/8 -12 UNF female F 562-C	19.1 [0.75]	9.7 [0.38]	41 [1.6]

Measuring ranges from 100 bar [1,500 psi] to 4,000 bar [60,000 psi]

Process connections for model UPT-21

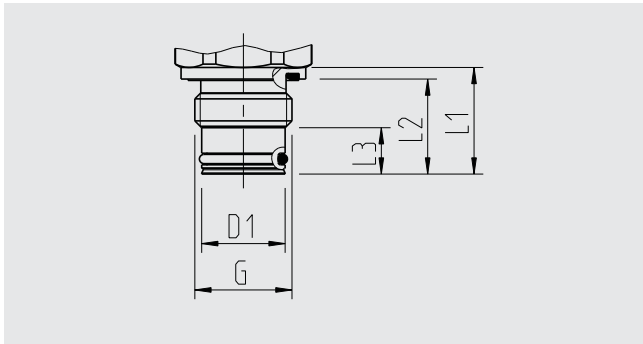

G	L1	L2	L3	D1
G ½ B	23 [0.9]	20.5 [0.81]	10 [0.4]	18 [0.71]

Hexagon dimension: 12 mm [0.47 in]
Spanner width: 27 mm [1.06 in]

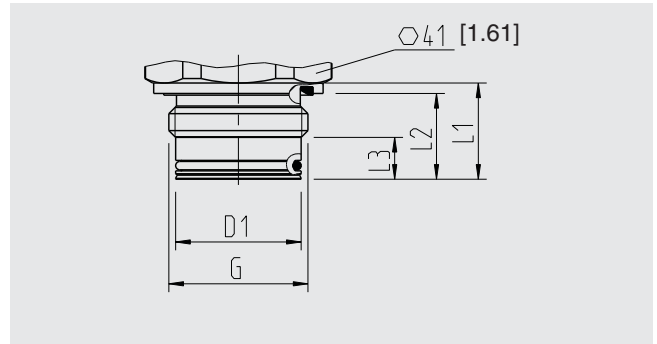

G	L1	L2	L3	D1
G 1 B	23 [0.9]	20.5 [0.81]	10 [0.4]	30 [1.18]

Hexagon dimension: 13 mm [0.51 in]

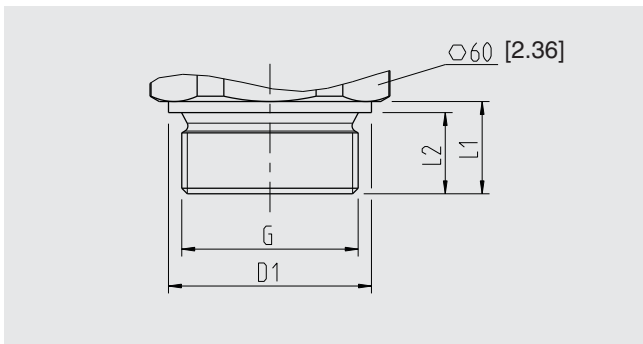

G	L1	L2	D1
G 1 ½ B	25 [0.99]	22 [0.87]	55 [2.17]

Hygienic

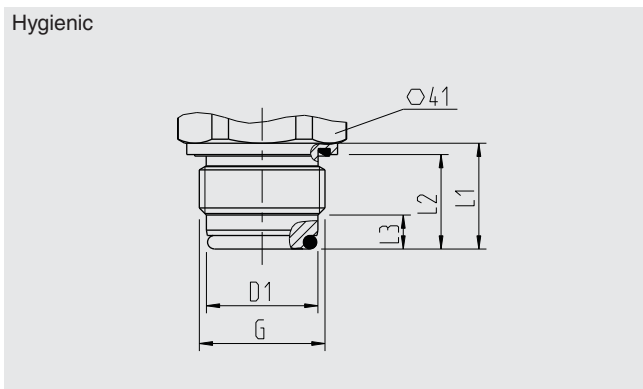

G	L1	L2	L3	D1
G 1 B	28 [1.10]	25 [0.98]	9 [0.35]	29.5 [1.16]

Hygienic

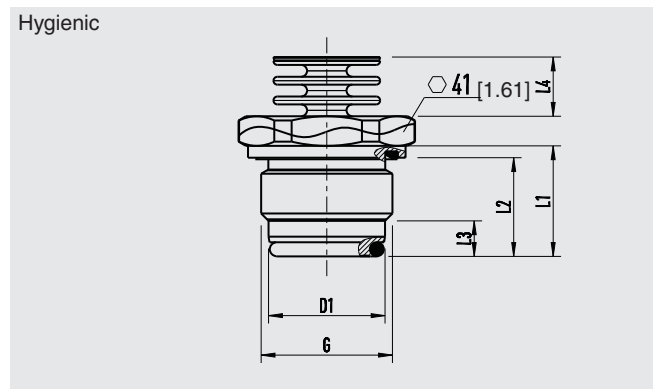

G	L1	L2	L3	L4	D1
G 1 B	28 [1.10]	25 [0.98]	9 [0.35]	15.5 [0.61]	29.5 [1.16]

Hygienic connections for food industry, pharmaceutical industry and sanitary applications

Clamp connection (clamp)

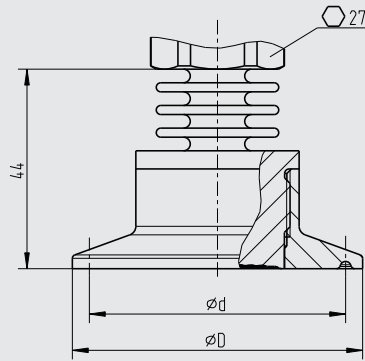

		$\varnothing D$	$\varnothing d$
DIN 32676 TRI-CLAMP® 1)	DN 1 ½	50.5 [1.99]	43.5 [1.71]
	DN 2	64 [2.52]	56.6 [2.23]
	DN 40	50.5 [1.99]	43.5 [1.71]
	DN 50	64 [2.52]	56.6 [2.23]

Hexagon height: 12.5 mm [0.49 in]

1) Process connections per ASME BPE

Grooved union nut DIN 11851 with conical coupling, for pipes per DIN 11850

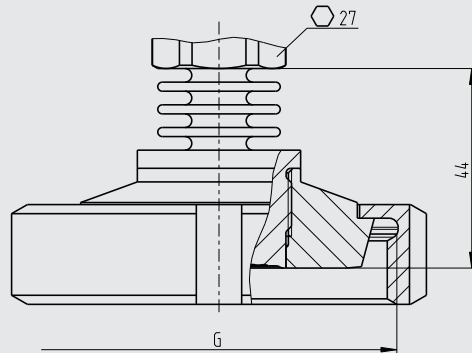

		G	$\varnothing d_3$
DIN 11851	DN 25	Rd 52 x 1/6	44 [1.73]
	DN 50	Rd 78 x 1/6	61 [2.40]

Hexagon height: 12.5 mm [0.49 in]

For a 3-A compliant connection of process connections with milk thread fittings per DIN 11851, profile sealings from SKS Komponenten BV or Kieselmann GmbH have to be used.

VARIVENT®

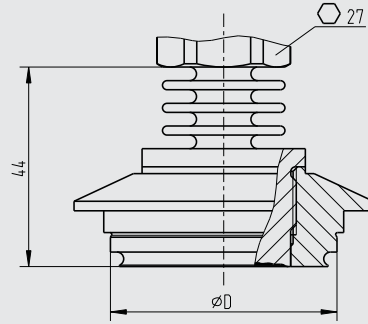

		ØD
VARIVENT®	Form F	50 [1.97]
	Form N	68 [2.68]

Hexagon height: 12.5 mm [0.49 in]

NEUMO BioConnect®
Flange, form V

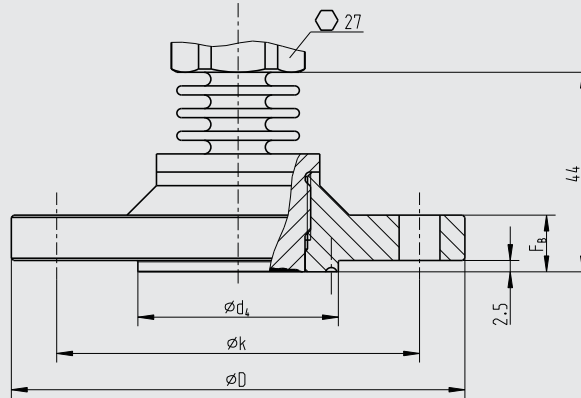

		Ød ₂	Ød ₄	ØD	Øk	F _B
BioConnect®	DN 40	4 x 9 [0.16 x 0.35]	44.2 [1.74]	100 [3.94]	80 [3.15]	10 [0.39]

Hexagon height: 12.5 mm [0.49 in]

DRD retainer flange

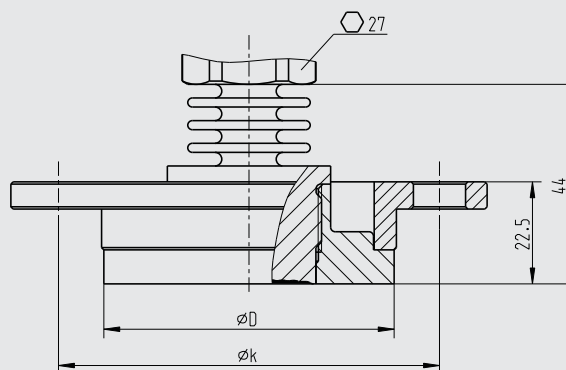

		ØD	Øk
DRD retainer flange	PN 40	64 [2.52]	84 [3.31]

Hexagon height: 12.5 mm [0.49 in]

Electropolished wetted surfaces for sanitary applications:

- Unpolished surface Ra ≤ 0.5 µm
- Polished surface Ra ≤ 0.38 µm

Case dimensions in mm

Plastic case, models UPT-20 and UPT-21

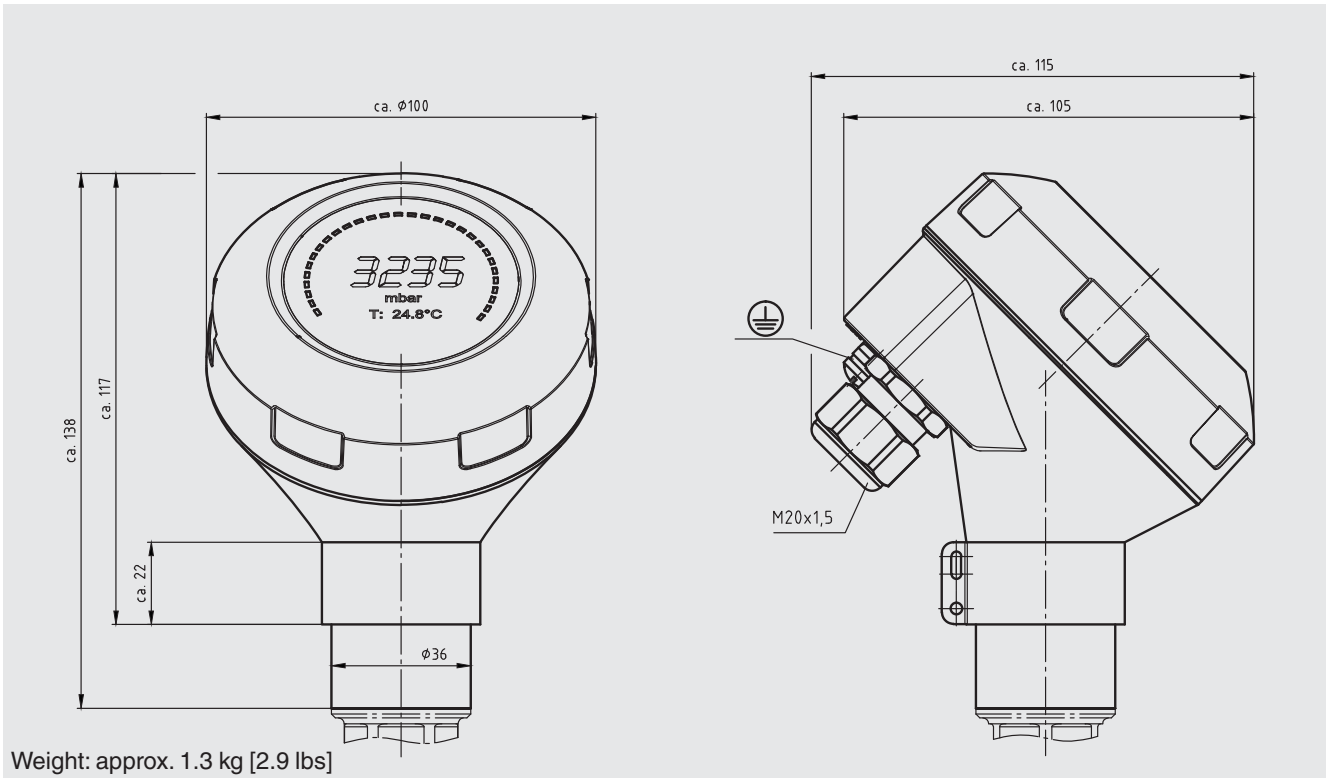

Stainless steel case and hygienic M20 x 1.5 cable gland, models UPT-20 and UPT-21

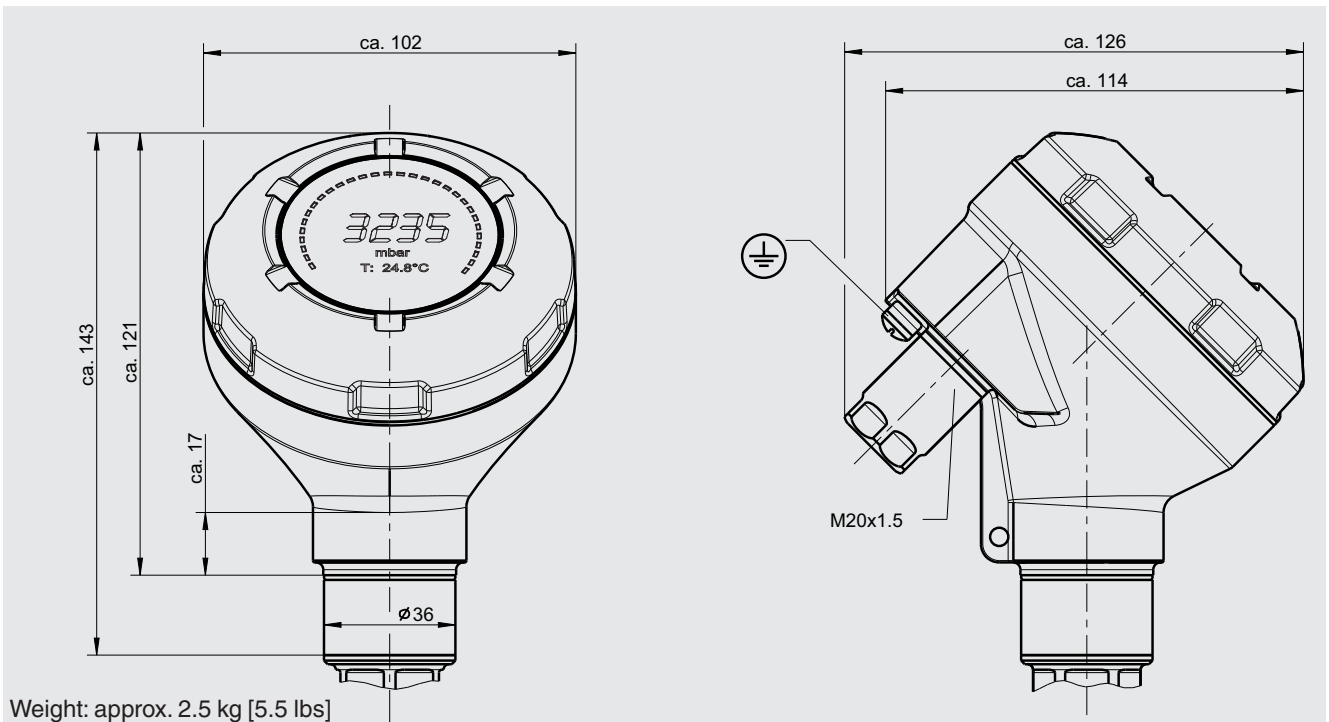

User interface DTM

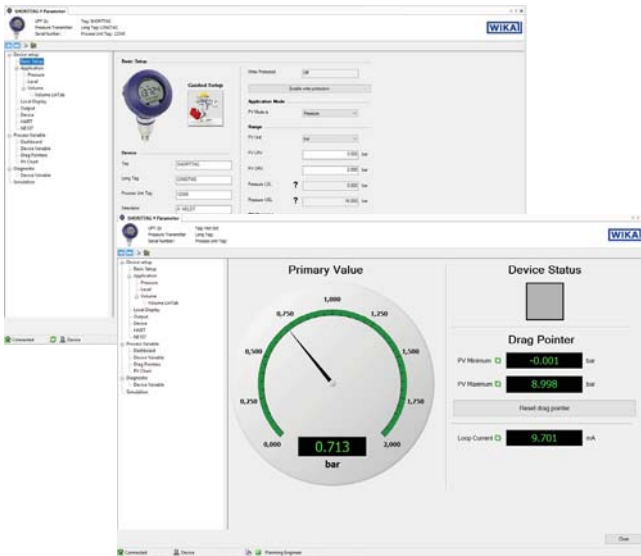





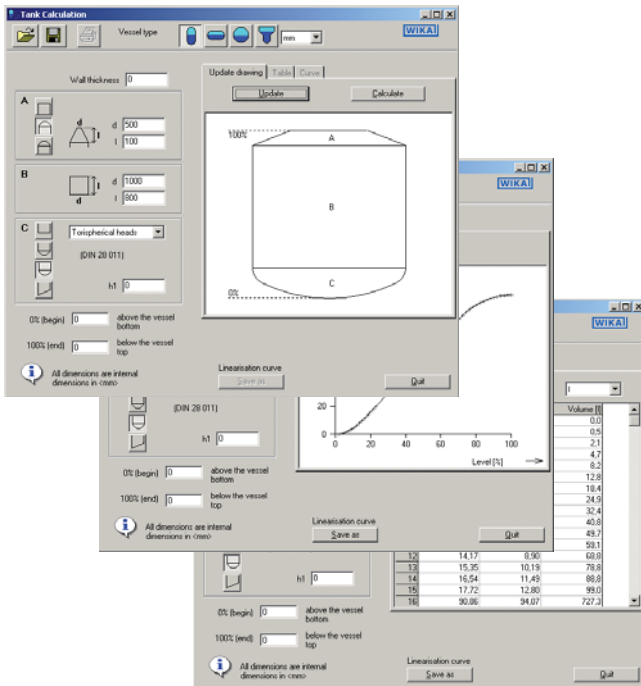



HART®出力信号については、FDT規格に準拠したDTMをご用意しております。DTMは、トランスミッタのすべてのセットアップおよび制御プロセスのための、自明で明確なユーザインターフェースを提供します。テストの目的で、プロセス値をシミュレートし、パラメータデータをアーカイブすることも可能です。測定値の記録を診断に利用することも可能です。

タンク容量計算

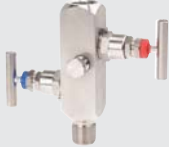

DTM機能の追加タンク容量計算は任意のオプションのタンク形状を再現するために使用することができます。対応する線形化テーブルが自動的に生成されます。線形化テーブルは、トランスミッタに直接転送することができます

Accessories

Description		Order number
	Display module, model DIH52-F 5-digit display, 20-segment bar graph, without separate power supply, with additional HART® functionality. Automatic adjustment of measuring range and span. Secondary-master functionality: Setting the measuring range and unit of the connected transmitter using HART® standard commands possible. Optional: Explosion protection per ATEX	On request
	HART® modem for USB interface, specifically designed for use with notebooks (model 010031) HART® modem for RS-232 interface (model 010001) HART® modem for Bluetooth interface Ex ia IIC (model 010041) PowerXpress HART® modem, with optional power supply (model 010031P)	11025166 7957522 11364254 14133234
	Welding socket For G ½ flush process connection For G 1 flush process connection For G 1 ½ flush process connection For G 1 hygienic flush process connection	1192299 1192264 2158982 14070973
	Instrument mounting bracket for wall or pipe mounting, stainless steel Weight: approx. 0.4 kg [0.9 lbs]	14058660
	Overvoltage protection for transmitters, 4 ... 20 mA, M20 x 1.5, series connection	14002489
	Display and operating unit, model DI-PT-U The display and operating unit can be attached in 90° steps. The display and operating unit features a main display and an additional display. The main display shows the output signal. The additional display shows different values, at the same time as the main display - these values can be selected by the user. The process pressure transmitter can be configured through the display and operating unit. Only this display may be used for installation into the process transmitter.	14090181
	Block-and-bleed valve, model IV20, IV21 See data sheet AC 09.19	
	Hygienic cable gland M20 x 1.5 Cable diameter: 6 ... 12 mm [0.24 ... 0.47 in]	11348691

Ordering information

Model / Explosion protection / Case version / Digital display / Output signal / Electrical connection / Measuring range / Process connection / Sealing / Wetted parts / Accuracy / Certificates / Scaling

© 04/2014 WIKA Alexander Wiegand SE & Co. KG, all rights reserved.
 The specifications given in this document represent the state of engineering at the time of publishing.
 We reserve the right to make modifications to the specifications and materials.



WIKAL
WIKAL Alexander Wiegand SE & Co. KG
 Alexander-Wiegand-Straße 30
 63911 Klingenberg/Germany
 Tel. +49 9372 132-0
 Fax +49 9372 132-406
 info@wika.com
 www.wika.com